



EXTRUDED POLYSTYRENE

INSULATION FOR WALK-IN COOLERS AND FREEZERS

EXTRUDED POLYSTYRENE

Extruded Polystyrene insulation is one of the two main insulation materials used in the manufacturing process for walk-in coolers and freezers. Extruded Polystyrene insulation is a closed-cell insulation structure with resistance to moisture absorption. These characteristics, along with its strength are what make Extruded Polystyrene the optimal choice for the cold storage industry.

Extruded Polystyrene has been used very successfully for several years in insulating areas of high moisture exposure and high R-value requirements.



EXCELLENT MOISTURE RESISTANCE

One of the largest factors that can affect the insulation's performance is moisture. When water starts collecting inside walk-in insulation, the R-value drops and moisture inside the insulation starts to freeze. When there are extreme environmental differences in the temperature of the inside and the outside of the walk-in, the insulation is vulnerable to retaining moisture in the structural voids.

As water has a much lower R-value than insulation, the water reduces the R-value of the insulation. As the R-value decreases, the unit's refrigeration system has to work even harder to hold the correct interior temperatures.

MAINTAINS A HIGH R-VALUE

Extruded Polystyrene's closed-cell structure and lack of voids results in a higher, longer lasting R-value. Extruded Polystyrene holds its R-value longer than other insulations. While other insulations only retain 25% of their R-value with 5 years, Extruded Polystyrene retains 75% of its R-value over 5 years.

IMPROVES ENERGY EFFICIENCY

The continual objective of the insulation in walk-ins is to maintain a high R-value which ultimately saves energy. Obtaining and maintaining the highest possible R-value is the key to achieving the highest energy efficiency over the life of the unit.

Extruded Polystyrene meets and exceeds the requirements for Energy independence and Security Act of 2007 and upcoming federal regulations.

DESIGN FLEXIBILITY

U.S. Cooler's walk-in cooler and freezer units are constructed to the customer's specific needs. Each panel is engineered to provide a durable, long-lasting service. The panels can be assembled quickly and easily. With our cam-action locking system, our units can be taken down for relocation or expanded as simply as they are installed.



GENERAL SPECIFICATIONS

GENERAL

All walk-ins are test assembled at the factory and include a set of installation instructions and a layout drawing. Each panel will have an identification number corresponding to the layout drawing to facilitate rapid and accurate field erection.

PANEL CONSTRUCTION

Each panel consists of inner and outer metal skins, a 4" insulation core, and is equipped with cam-action locking devices. Construction is as approved by the National Sanitation Foundation International and bears the NSF® Seal of Approval. All panels shall be connected to one another by placing the tongue of the insulation core of one panel into the groove of the core insulation of the adjacent panel. The resultant tongue and groove joint shall be sealed at both sides by double barreled NSF® approved gaskets. To avoid future swelling and mold formation, no wood shall be permitted in the manufacture of the tongue and groove panel profile.

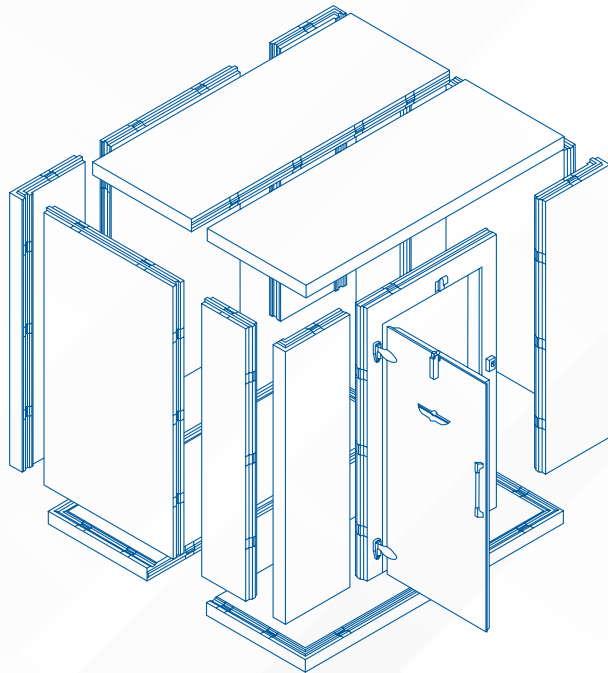

COOLER & FREEZERS

All wall and ceiling insulation is 4" thick, high quality, rigid extruded polystyrene, 1.6 lb density.

For Coolers: The R-factor will be at least 7.2 per inch making the R-value of the panels equal or greater than R-28.8.

For Freezers: The R-factor will be at least 8 per inch making the R-value equal or greater than R-32.

Vapor transmission shall be less than 1 perm and foam core material must meet: Owens Corning - UL Foam Core 5 flame spread rating with average smoke rating less than 175. (UL 723)

DuPont - UL Foam Core 15 flame spread rating with average smoke rating less than 165. (UL723)

CONSTRUCTION:

Modular Panels are connected with cam-lock connectors. All walls, ceilings, and floor panels use no wood unless otherwise noted. All walk-ins are EISA compliant.

INSULATION:

4" extruded polystyrene or 4" foamed-in-place polyurethane. Panel insulation shall be foamed-in-place polyurethane, made from CFC and HFC free materials.

SKIN:

26ga. galvanized, galvalume, painted or 24 ga. stainless steel.

DOORS:

Self closing, flush mount with magnetic gasket; chrome latches and hinges; vertical handle, safety release handle, automatic self closer, vapor proof light and thermometer.

FLOORS:

22ga. stainless steel (Extruded Polystyrene) .100 aluminum (Foamed-In-Place Polyurethane)

REFRIGERATION:

All sizes, remote, side mount, top mount, indoor, outdoor.

OPTIONS:

Rain roof, shelving, glass doors, lighting, strip curtains, viewing windows, alarms and more can be purchased through our sales department.

WARRANTY:

Limited 10 year panels, 1 year parts.

*Specifications subject to change without notice. Item drawn may not be exactly as shipped.

