



FOAMED-IN-PLACE POLYURETHANE

INSULATION FOR WALK-IN COOLERS AND FREEZERS

FOAMED-IN-PLACE POLYURETHANE

Foamed-in-Place Polyurethane insulation is commonly used as the insulation in the manufacturing process for walk-in coolers and freezers. U.S. Cooler's 100% polyurethane panels are made from CFC and HFC free materials with minimal environmental impact.



SUPERIOR QUALITY

U.S. Cooler's polyurethane walk-in products are made with the same exceptional quality and performance construction that has proven successful in the industry for over 25 years. Every walk-in is pre-assembled in our manufacturing facility before shipment to ensure precise quality control and ease of assembly in the field.



DESIGN FLEXIBILITY

U.S. Cooler's walk-in cooler and freezer units are constructed to the customer's specific needs. Each panel is engineered to provide a durable, long-lasting service. The panels can be assembled quickly and easily. With our cam-action locking system our units can be taken down for relocation or expanded as simply as they are installed. U.S. Cooler offers several interior and exterior metal options to conform to your design requirements for decor and durability.

EXCEPTIONAL PERFORMANCE

U.S. Cooler's Foamed-in-Place Polyurethane performance rating of R-32 for freezers meets the Energy Independence and Security Act and exceeds the R-25 requirement for coolers. Its 97% closed cell structure resists moisture from seeping into the insulation which helps maintain the high R-value. By utilizing state-of-the-art horizontal presses and technology, panels lie flat during the foaming process which reduces voids in the insulation. The panels' structural tongue and groove, cam-locking system provides an air-tight seal between the panels restricting air infiltration into the insulation core. Foamed-in-Place Polyurethane manufacturing techniques present a uniform adhesion to the metal skins causing the insulation to continuously adhere.



GENERAL SPECIFICATIONS

GENERAL

All walk-ins are test assembled at the factory and include a set of installation instructions and a layout drawing. Each panel will have an identification number corresponding to the layout drawing to facilitate rapid and accurate field erection.

COOLER & FREEZERS

Foamed-in-Place Polyurethane: All insulation shall be 4" thick, high quality, rigid polyurethane, 2.2 lb density.

For Coolers: K factor of not more than .141 and an R-factor of not less than 7.1 per inch, initial fresh R-28.4 minimum total wall R factor.

For Freezers: K Factor of no more than .125 and an R Factor of no less than 8 per inch, initial fresh R-32 minimum total wall R Factor.

For Cooler and Freezers: Vapor transmission shall be less than 1 perm and foam core material must meet UL Foam Core 20 flame spread rating with average smoke rating less than 450. (ASTM E-84) UL 1715 Certified listed with Intertek/ETL (optional)

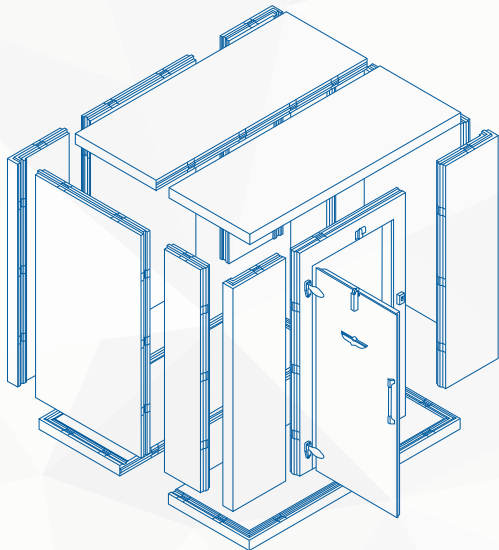

PANEL CONSTRUCTION

Each panel consists of inner and outer metal skins, a 4" insulation core, and is equipped with cam-action locking devices. Construction is as approved by the National Sanitation Foundation International and bears the NSF® Seal of Approval. All panels shall be connected to one another by placing the tongue of the insulation core of one panel into the groove of the core insulation of the adjacent panel. The resultant tongue and groove joint shall be sealed at both sides by double barreled NSF® approved gaskets. To avoid future swelling and mold formation, no wood shall be permitted in the manufacture of the tongue and groove panel profile.

CONSTRUCTION:

Modular Panels are connected with cam-lock connectors. All walls, ceilings, and floor panels use no wood unless otherwise noted. All walk-ins are EISA compliant.

INSULATION:

4" extruded polystyrene or 4" foamed-in-place polyurethane. Panel insulation shall be foamed-in-place polyurethane, made from CFC and HFC free materials.

SKIN:

26ga. galvanized, galvalume, painted or 24 ga. stainless steel.

DOORS:

Self closing, flush mount with magnetic gasket; chrome latches and hinges; vertical handle, safety release handle, automatic self closer, vapor proof light and thermometer.

FLOORS:

22ga. stainless steel (Extruded Polystyrene) .100 aluminum (Foamed-In-Place Polyurethane)

REFRIGERATION:

All sizes, remote, side mount, top mount, indoor, outdoor.

OPTIONS:

Rain roof, shelving, glass doors, lighting, strip curtains, viewing windows, alarms and more can be purchased through our sales department.

WARRANTY:

Limited 10 year panels, 1 year parts.

*Specifications subject to change without notice. Item drawn may not be exactly as shipped.