



Quanta CrossFire™

SMD

LED Display Lighting Systems



Quanta CrossFire introduces the streamlined, lightweight and washable SMD.
(Power Factor Corrected)

Quanta CrossFire LED fixtures throw a strong and un-patterned light deep into the display case and not into the store. Quanta CrossFire delivers no less than 1300lx to the edge of the center of the top and bottom shelf.

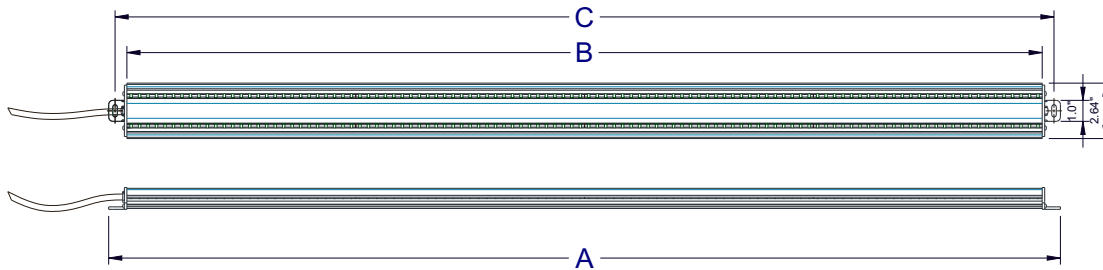

	A Total length	B Casing length	C Hole distance	Wattage	Amp* rating	Weight
4160-120-LP	45.33"	43.85"	44.72"	7.5 w	.06	1 lb 2.5 oz
4160-120-RP	45.33"	43.85"	44.72"	7.5 w	.06	1 lb 2.5 oz
5160-120-LP	56.23"	54.75"	55.62"	7.5 w	.06	1 lb 7.2 oz
5160-120-RP	56.23"	54.75"	55.62"	7.5 w	.06	1 lb 7.2 oz
6160-120-LP	67.13"	65.65"	66.52"	9.0 w	.075	2 lb 3.1 oz
6160-120-RP	67.13"	65.65"	66.52"	9.0 w	.075	2 lb 3.1 oz

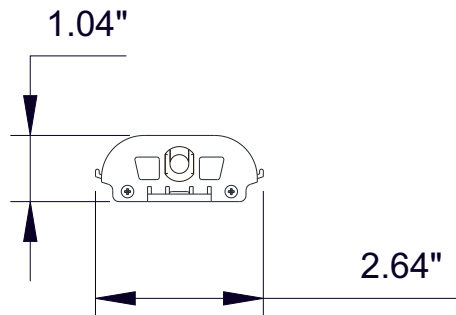

Avg life	CRI	Color temp	Power factor	THD	Voltage	LED per PCB	Length of whip
50,000 hours	80	3500K 4100K 5000K	0.997 lagging	<5%	120V	21	24"

Warranty: 5 years from date of manufacture; repair or replacement (for further details see our warranty document)

Meets NSF, UL 1598 and Class A FCC Title 47, Sub part B, Section 15.